

MADELL QK982 SYRUP DISPENSER

OPERATING MANUAL

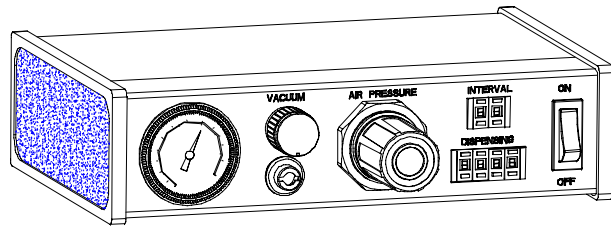

The QK982 syrup dispenser can be used with different syrups as glues, greases, solder pastes, etc. Supplied with 10 types of steel tips and 5 types of plastic tips for various applications.

1. Specifications

Dispensing Modes	Automatic and manual with a total of 16 combinations
Dispensing Time	0.01-99.99 seconds adjustable
Timing Intervals	0.1-9.9 seconds adjustable
Repeat Tolerance	$\pm 0.05\%$
Size	23.8X15.0X6.0cm
Weight	1.7Kg
Internal Voltage	24V DC
Air Input	35-100Psi (0.25-0.7MPa)
Air Output	1-100Psi (0.01-0.7Mpa)

2. Operation

(1) Features

1. Power Switch, unit on or off switch.
2. Timing Interval switch, timing intervals control.
3. Air Pressure Regulator, air pressure control.
4. Vacuum Control, "suck back" vacuum control.
5. Air Pressure Gauge, air pressure indicator.
6. Dispense Outlet, quick connect receptacle.
7. Dispensing Sliding Switch, syrup output and time interval control
8. Air-in Tube, compressed air input
9. Footswitch.
10. Model Switch, manual, automatic and other modes selection.
11. Power Connector.

(2).Diagram of front and rear panels

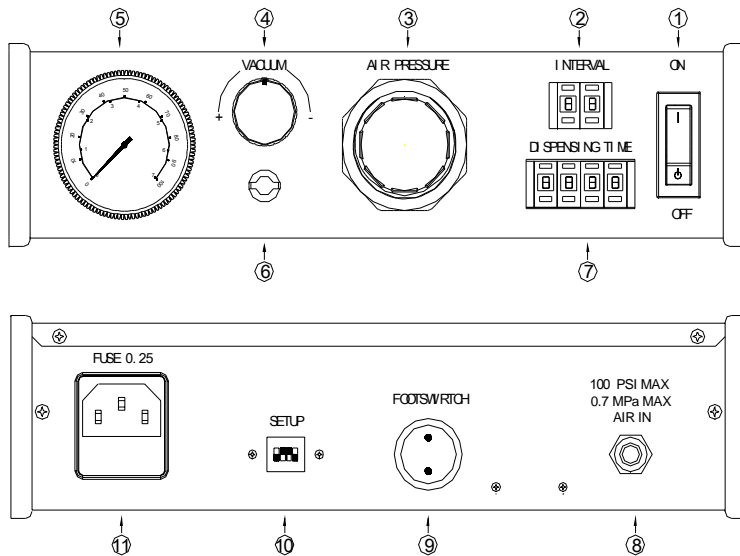

(3)Adjustment of dispensing time and interval time

Mode switch on the rear panel of the unit can be adjusted according to the following table to suit different needs.



(a). Adjustment of dispensing time and interval time.

The dispensing time control button is located on the front panel of the unit. The dispensing time can be set directly. Press the “+” button, and the corresponding digit will increase by one. Similarly, press the “-” button, the corresponding digit will decrease by one. There are four digits in the display, with a range from 0.01 second to 99.99 seconds, and the resolution is 0.01 second.

(b). Interval Time Setup

The interval time control button is located on the front panel of the unit. The interval time can be set directly. Press the “+” button will increase the interval by one. Similarly, press the “-” button will decrease the interval by one. There are two digits in the display, with a range from 0.1 second to 9.9 seconds, and the resolution is 0.1 second.

Item No.	Mode Switch Status				Function
	S1	S2	S3	S4	
1	OFF	OFF	OFF	OFF	With pedal switch pressed, dispense continuously, otherwise it will stop dispensing.
2	ON	OFF	OFF	OFF	Be triggered once, dispense at controlled time once.
3	OFF	ON	OFF	OFF	Be triggered once, dispense at controlled time twice.
4	ON	ON	OFF	OFF	Be triggered once, dispense at controlled time three times.
5	OFF	OFF	ON	OFF	Be triggered once, dispense at controlled time four times.
6	ON	OFF	ON	OFF	Be triggered once, dispense at controlled time five times.
7	OFF	ON	ON	OFF	Be triggered once, dispense at controlled time six times.
8	ON	ON	ON	OFF	Be triggered once, dispense at controlled time seven times.
9	OFF	OFF	OFF	ON	Be triggered once, dispense at controlled time eight times.
10	ON	OFF	OFF	ON	Be triggered once, dispense at controlled time nine times.
11	OFF	ON	OFF	ON	Be triggered once, dispense at controlled time ten times.
12	ON	ON	OFF	ON	Be triggered once, dispense at controlled time eleven times.
13	OFF	OFF	ON	ON	Be triggered once, dispense at controlled time twelve times.
14	ON	OFF	ON	ON	Be triggered once, dispense at controlled time continually, the next trigger will stop dispensing.
15	OFF	ON	ON	ON	With pedal switch pressed, dispense at controlled time continually, or it will stop dispensing.
16	ON	ON	ON	ON	Dispense at controlled time continually and automatically.

Note: Dispensing at controlled time means dispensing according to set dispensing time and interval time.

(4) Internal air pressure control

The air pressure regulation knob controls internal air pressure. Air pressure at 0.1-2.7bar (1-40Psi) is normally used.

(5) Vacuum control

The vacuum control knob regulates the ending dot in the air reflection, avoid connected dots. Turn the knob clockwise will increase air reflection, otherwise, it will decrease.

(6) Set up

1. Connect the 7 bar dry and filtered air supply to the unit's air input plug.
2. Fill the barrel with syrup. Make sure the syrup level is not over the FULL line,

(6) Operation

1. Turn the unit "on" by switching the red power to on position.
2. Pull the air pressure regulator knob outward and turn clockwise until the desired air pressure is indicated.
3. Set the mode switch to proper position, referring to the adjustment of dispensing time and interval time.

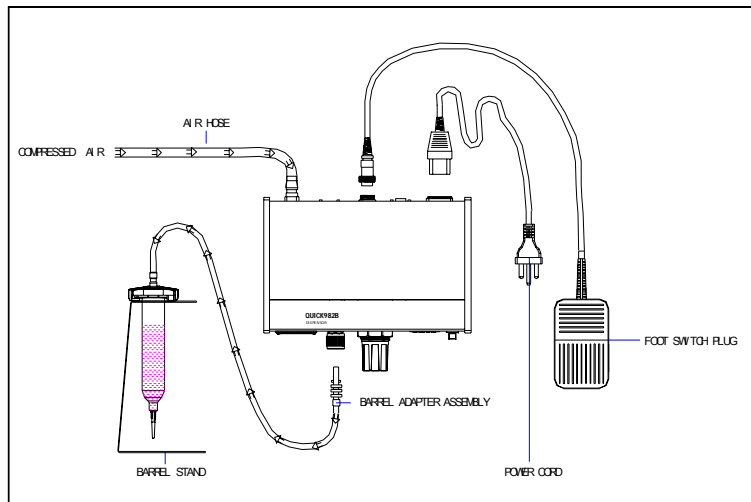

3. Helpful hints for making Proper deposit

1. Hold the barrel at approximately 60° (+ or -20°) angle (FIG1)
2. Lift the dispenser barrel vertically after making a drop, as shown (FIG2)
3. Do not let the syrup flow back into the controller as shown in FIG3.
4. Increase or decrease dot size by either,
Increase or decrease time only,
Or
Increase or decrease pressure only,
Or
Increase or decrease size of the tip.

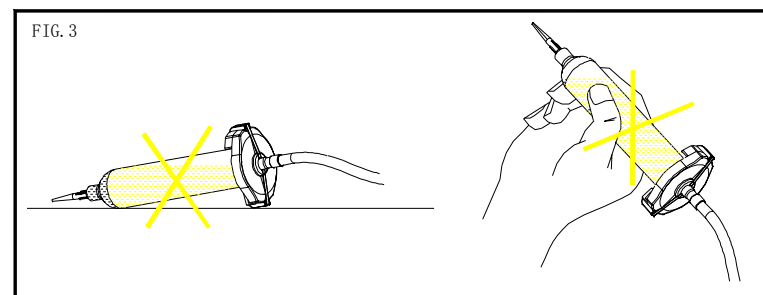
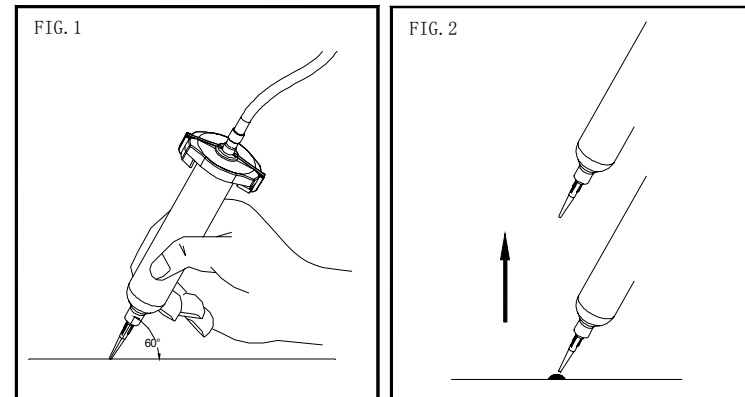

4. Cautions

1. The dispensed syrup maybe toxic and/or hazardous, refer to manufacturer's instructions for proper handling and safety precautions.
2. Compressed air pressure should not exceed 7 bar (100Psi). Otherwise, it will cause negative effects (damage to objects or injury to the user).
3. Make certain air supply is clean and dry.
4. Syrup should be kept above 5°C to avoid change in density. Otherwise, the syrup will be hard to dispense and proper dots can not be formed.
5. The air pressure should be regulated at 0.1-0.27Mpa (15-40Psi).
7. Clean the dispenser tip regularly.
8. The suck-back vacuum should be adjusted in conjunction with air pressure, dispensing cycle and drop size. Too stronger vacuum will break the dispensed lines, cause running back of the syrup through the controller, resulting in permanent damages to the unit.
9. Avoid turning barrels upside down or lay down on its side. Syrup may run through air line to inside of the dispenser and cause component damages.
10. Avoid hit the plastic barrel assemblies with hot or sharp objects.
11. Avoid exposing the dispenser to excessive moisture or solvent.
12. After use, clean the barrel and needles as soon as possible by soaking them in clean water for 5-10 minutes.

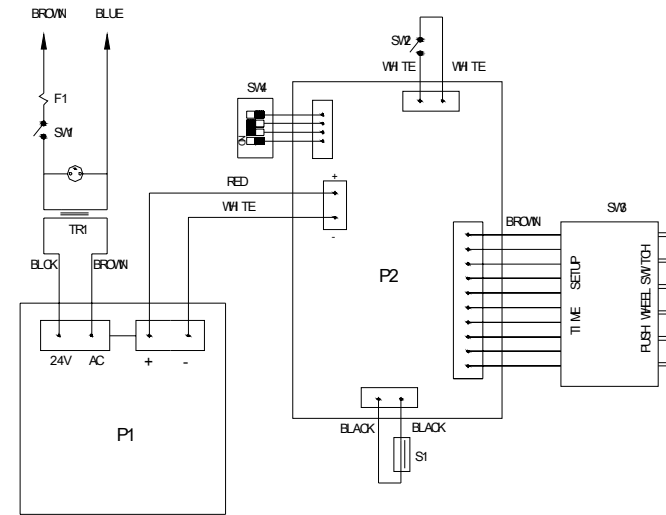

1. Electrical Theory Schematic

3. The dispensing controller electrical schematic

1. Parts List

Symbol	Description	Part No.
F1	Fuse, 0.25Amp	
P1	Potionmeter	47087
P2	Controlling PCB	47166
S1	Solenoid Valve	26036
SW1	Power switch	12034
SW2	Foot pedal switch	47024
SW3	Time setup switch	12040
SW4	Mode Switch (DIP Switch)	47164
TR1	Transformer 110V/24V	18035
	Transformer 220V/24V	18036
	Transformer 230V/24V	18037

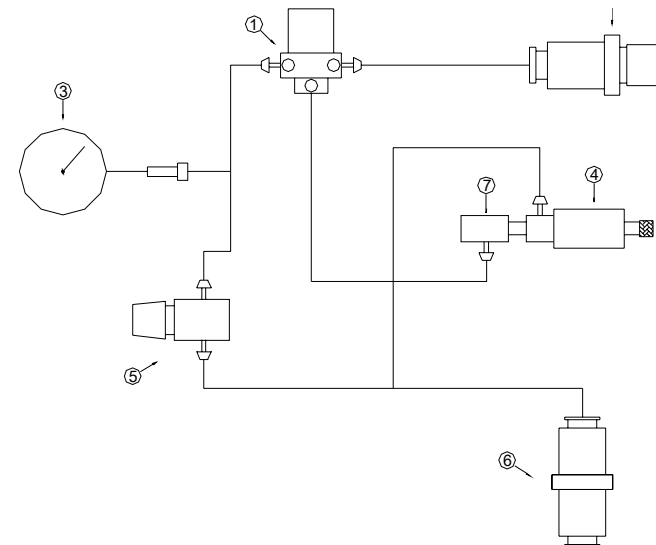

1.Theory Schematic of pneumatic system.

4. The dispensing controller pneumatic system.

1. Parts List

Symbol	Description	Part No.
1	Solenoid valve	26034
2	Dispensing socket	47165
3	Air pressure gauge	26035
4	Vacuum regulator	47163
5	Air pressure regulator	26036
6	Air-in manifold	44122

5. Trouble shooting

Problem	Check or correction
No power	<ol style="list-style-type: none"> 1.Check wall socket for power supply 2.Check fuse. 3.Unplug from wall. remove top cover ,visually inspect for any loose or short connection.
Power on, but no light	replace power switch
Power light on, does not operate	<ol style="list-style-type: none"> 1.Check foot switch connection. 2.Unplug from power supply, remove top cover and check for loose connection.
Power light on, does not dispense	<ol style="list-style-type: none"> 1.Check air supply and pressure gauge. reset the regulator if necessary, remove barrel from adapter .Depress foot switch to check air flow. 2.If solenoid clogged with foreign object from air compressor, clean or replace it.
Solenoid buzzes	<ol style="list-style-type: none"> 1.Voltage is too low 2.Air supply is insufficient. 3.Solenoid is not clean.
Burnt fuse	<ol style="list-style-type: none"> 1.Checking fuse specifications. 2.Unplug power input, remove cover, and check internal wiring for loose connection.
Inconsistent dots	<ol style="list-style-type: none"> 1.Check needles tip, barrel, adapter and material for possible clogging. 2.Check for air bubbles in the syrup. 3.Check air gauge for air pressure variation.
Dispensing ok, but no vacuum in dispense circuit	<ol style="list-style-type: none"> 1.Check vacuum setting. 2.Check air pressure setting(must be 30-40Psi,0.2-0.27Mpa)

6. Parts list

No.	Description	Unit	Quantity	Part No.
1	Piston	piece	1	25023
2	35cc barrel	piece	1	25024
3	35cc adapter (+1.0m clean tube)	set	1	47089
4	Needle(10pieces/set)	set	1	25025
5	Power cable	CCC	piece	1
		USA		
		VDE/CE		
6	Foot switch (include two cores plug)	set	1	47024
7	“O” ring	piece	1	26041
8	Instruction manual	set	1	
9	Barrel rack	piece	1	43035
10	Air-input tube (3m)	set	1	26040
11	Adapter (match the barrel which cannot be connected with the adapter)	piece	1	42073
12	Fuse	200-240V/0.25A	piece	1
		110V/0.5A		

